

Visual Signals - Light Commercial LED ECO BEACONS

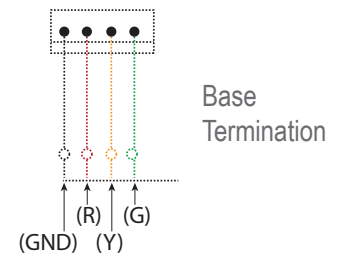
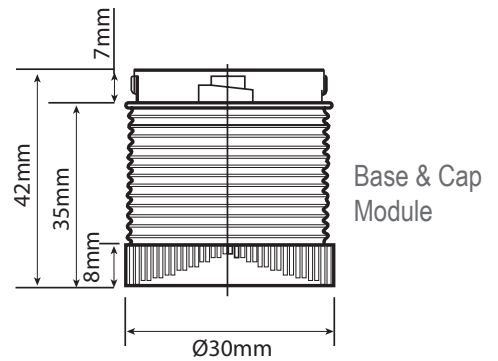
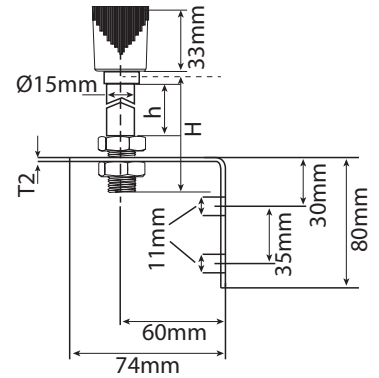
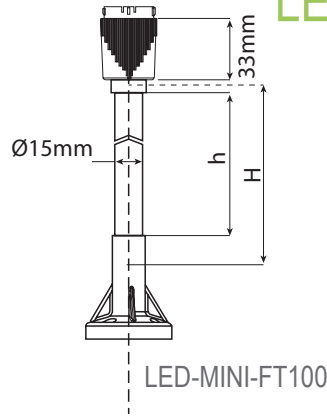

Light Commercial LED ECO Beacons > LED-MINI Series (30mm diameter)

Product overview.

The LED Mini Tower Light modules are ideally suited for status indication in light commercial signalling applications where a low cost, compact and local signal is required. These Beacons are of the continuous (Static Mode) type (Single Stage Alarm) and once the Beacon is energised, the LED's stay permanently on.

An advantage to this type of operation, is that it can be controlled via a remote source (Control Panel or PLC etc) giving

this Beacon greater flexibility by offering a Second Stage Alarm (Flashing)

The design is modular and easily assembled. The units assemble using a twist lock system allowing for quick and easy assembly. All colour modules are supplied with quick fix terminations via an IDC lead that simply push into a male terminal to make the connection.

Two mounting options are available: Mounting Foot & 100mm Pole or a Side Fix Bracket with 100mm Pole. Each Base is supplied with a 1 meter flying lead.

LED-TLM Series > Ordering Information

Code No:	Voltage:	Light Source:	Current:
LED-MINI-02	12/24v Dc ---	8 SMT LEDs	80mA • 45mA ••
LED-MINI-FT100	Mounting Base, Foot & Pole 100mm		
LED-MINI-BR100	Mounting Base, Bracket & Pole 100mm		

- @ 12v
- @ 24v

ADD THE FOLLOWING LENS CODES TO THE PRODUCT WHEN ORDERING



Features

- Continuously rated
- LED long life
- Low current consumption
- Economical
- 360° light output around the vertical axis

Material

UV Stable Polycarbonate Lens
UV Stable Polycarbonate Base

Kg 0.2 Module
0.23 Bracket
0.15 Foot

°C -20+66

IP 54

APPROVALS and
CONFORMITIES

